

# Socket Clamp

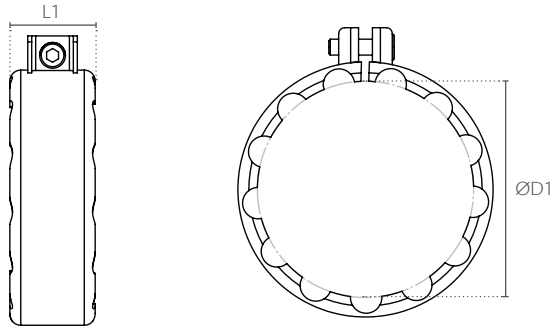

Socket Clamp with One Part



Socket Clamp with Two parts

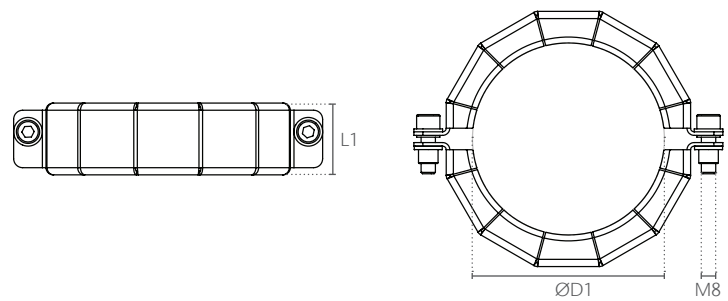

	Part no.	Length (L1) in (mm)	ØD1 in (mm)	Pipe Material	Weight lbs
Socket Clamp with One Part	<b>417067</b>	1.58 (40)	1.97 (50)	316L	0.2
	<b>417069</b>	1.70 (43)	2.95 (75)	316L	0.4
	<b>417227</b>	1.70 (43)	4.33 (110)	316L	0.7
Socket Clamp with Two Parts	<b>417397</b>	1.42 (36)	1.57 (40)	316L	0.4
	<b>417025</b>	1.58 (40)	1.97 (50)	316L	0.4
	<b>417027</b>	1.58 (40)	2.95 (75)	316L	0.5
	<b>417029</b>	1.70 (43)	4.33 (110)	316L	0.6
	<b>417017</b>	1.78 (45)	4.92 (125)	316L	0.8
	<b>417031</b>	1.78 (45)	6.30 (160)	316L	1.3
	<b>419983</b>	1.78 (45)	7.87 (200)	316L	1.1
	<b>417137</b>	1.78 (45)	9.84 (250)	316L	1.6
	<b>417219</b>	1.89 (48)	12.40 (315)	316L	2.1

## Specification Summary

Used with ACO Pipe System. Used to mechanically secure ACO push-fit piping system. Made from AISI 316L. Designed for gravity piping system with maximum working pressure of 0.5 bar. Socket clamp can increase maximum operating pressure to 0.7 bar. Only Available in metric ACO Pipe sizes listed below. ACO recommends checking local plumbing codes prior to installation. Manufactured to EN 1124-1 and 1124-2.

## ACO, Inc.

© January 2026 ACO, Inc.

All reasonable care has been taken in compiling the information in this document. All recommendations and suggestions on the use of ACO products are made without guarantee since the conditions of use are beyond the control of the company. It is the customer's responsibility to ensure that each product is fit for its intended purpose and that the actual conditions of use are suitable. ACO, Inc. reserves the right to change products and specifications without notice.

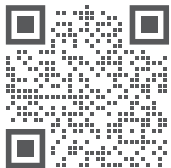

info@acousa.com  
www.acousa.com

